

HISTORY OF CONSTRUCTION
40 CFR 257.73(c)(1)(i)-(xii)
PLANT MCINTOSH ASH POND 1
GEORGIA POWER COMPANY

(i) Site Name and Ownership Information:

Site Name: Plant McIntosh

Site Location: Rincon, Georgia
Site Address: 981 Old Augusta Road Central
Rincon, GA 31326

Owner: Georgia Power Company
Owner Address: 241 Ralph McGill Blvd
Atlanta, GA 30308

CCR Unit Name: Plant McIntosh Ash Pond 1 (AP-1)
NID ID: Cell A: GA05892, Cell B: GA05896, Cell C: GA05897,

EPA's "Disposal of Coal Combustion Residuals from Electric Utilities" Final Rule (40 C.F.R. Part 257 and Part 261), §257.73(c)(1), requires the owner or operator of an existing CCR surface impoundment to compile a history of construction. To the extent feasible, the following information is provided:

(ii) CCR Unit Location Map:

32°21'02"N, 81°10'18"W
See Location Map in the Appendix

(iii) Purpose of CCR Unit:

Plant McIntosh is an electric generating facility with 1 coal fired unit and 8 simple cycle combustion turbine generators. AP-1 receives and stores coal combustion residuals (CCR) and low-volume waste produced during the electric generating process at Plant McIntosh.

(iv) Watershed Description:

Plant McIntosh AP-1 is located within the Dasher Creek – Savannah River HUC-12 watershed which has a total area of 56,186 acres. Plant McIntosh property is located within the Lower Savannah HUC-8 watershed which has a drainage area of 643,105 acres. AP-1 consists of a drainage area of approximately 26 acres with no additional off-site areas contributing to the total drainage area.

(v) Description of physical and engineering properties of CCR unit foundation/abutments:

AP-1 is subdivided into four cells, known as Cells A, B, C, and D. Cells A, B, and C serve as storage and settling cells, and Cell D serves as a clear pond. The main impoundment dikes are interconnected along the perimeter of AP-1. The west dike separates AP-1 from Plant McIntosh Road and is approximately 2,200 ft. along Cell A and Cell D. The northern, eastern, and southern dikes are approximately 600 ft., 1,480 ft., and 550 ft. long, respectively. The dikes are generally homogenous structures comprised of low permeability compacted fill supported above the natural soil, with a constant top of dike elevation of 62.5 ft. The interior slopes are at 2H:1V while the exterior slopes are variable with minimum slopes of 3H:1V.

AP-1 lies within the Coastal Plain province. The topography of the Coastal Plain is relatively flat and featureless, generally sloping towards the sea. The foundation and abutments are supported by naturally deposited soils consisting generally of soft to very stiff sandy clayey silt and silty clay with discontinuous sand lenses and very loose to firm clayey and silty fine sand. These soils are underlain by very firm to very dense silty sand and hard to very hard sandy silt. The residual soils' consistency generally increases with depth.

Geotechnical explorations and stability analyses for the planned ash pond were conducted prior to construction. Engineering design parameters were obtained from samples collected and tested during these investigations. Acceptable fill material was identified as cohesive soils with at least 30% material passing the No. 200 sieve, minimum PI of 20%, and no organics. The report stated that fill material should be placed in maximum 6 inch lifts compacted to a minimum of 97% of the Standard Proctor (ASTM D-698) maximum dry density and a moisture content between -1% to +3% of the Standard Proctor optimum moisture content.

(vi) Summary of Site Preparation and Construction Activities:

AP-1 was created by construction of containment berms separating Cells A, B, C, and D, each with a top elevation of 62.5 feet. The containment berms were originally constructed in 1982 creating a storage area of about 22 acres.

A summary of the plan for construction included stripping all topsoil and loose grey silty fine sand containing roots or other organic matter to an extent of at least 5 feet beyond the planned location of the dike toes and varying in depth. Additionally, it was recommended that the upper loose to firm light brown silty fine sand layer generally 1 to 3 feet in thickness should be stripped from the pond and dike areas to potentially be stockpiled and used as structural fill if mixed with cohesive soils. At the end of construction, surface soils were to be covered with approximately 6 inches of topsoil.

(vii) Engineering Diagram:

The following drawings reflecting the construction of AP-1 can be found in the Appendix:

- Site location map

- Savannah Electric and Power Co. Drawing C-10 – Grading and Drainage Plan – Loop Track Area
- Savannah Electric and Power Co. Drawing C-12 – Grading and Drainage Sections
- Savannah Electric and Power Co. Drawing C-13 – Drainage Details
- Savannah Electric and Power Co. Drawing S-19 – Ash Pond Pump Structure
- Savannah Electric and Power Co. Drawing S-25 – Discharge Structure Type I Plans, Sections and Details
- Savannah Electric and Power Co. Drawing S-26 – Discharge Structure Type II Plans, Sections and Details
- Georgia Power Company Drawing ES1896S2
- Savannah Electric and Power Co. Drawing 11940-FY-11A-1 – Ash Pond Dikes Plan & Sections

(viii) Description of Instrumentation:

There are 4 piezometers installed along the main impoundment dikes at AP-1 that are used to monitor water levels around the impoundment.

(ix) Area-capacity curves:

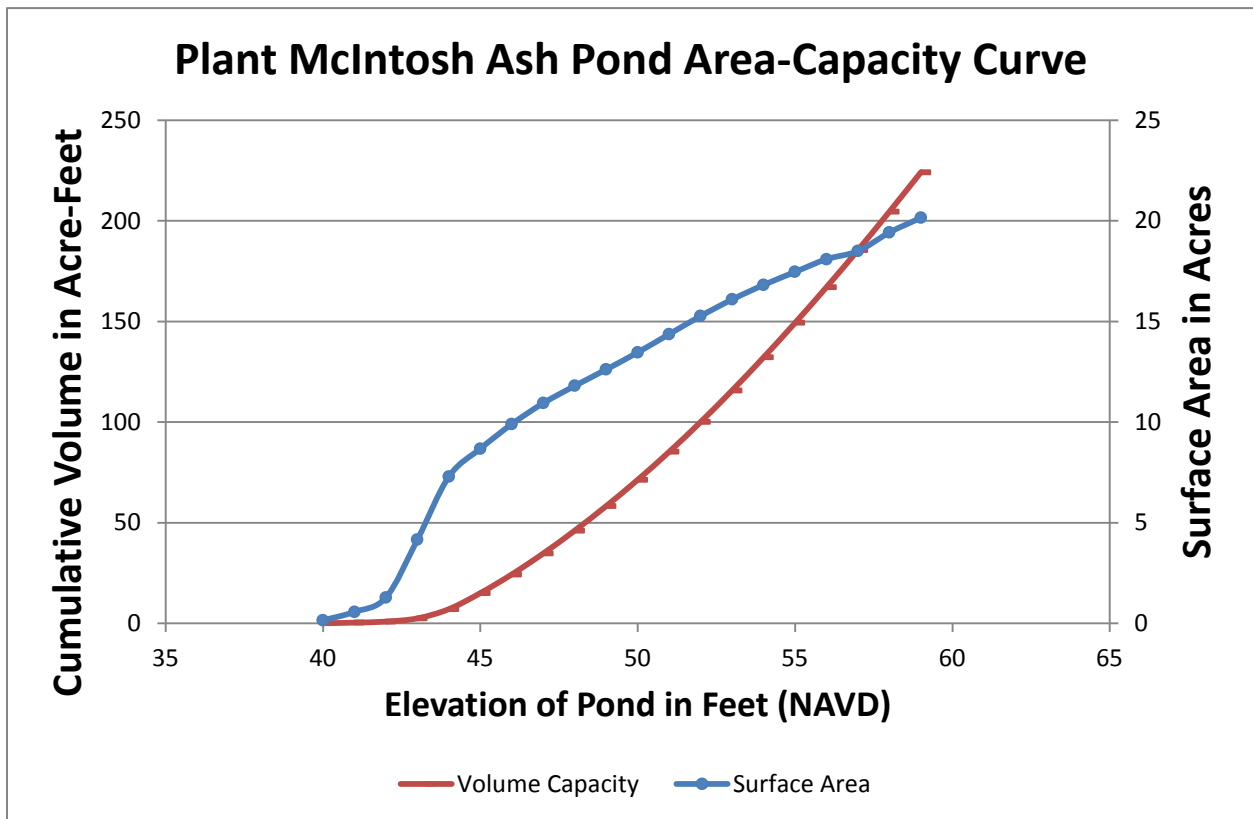

(x) Spillway/Diversion design features and capacity calculations:

The primary discharge structure for AP-1 is located in the southern portion of Cell D. Return water pumps are located at Cell D for routing process water back to the Plant. The normal water surface elevation within AP-1 is 59.0 feet. The design storm for AP-1 is the 100-year, 24-hour storm. During this event, the water surface elevation peaks at 60.4 feet or 1.2 feet below the top of the dike. The primary discharge structure is a riser structure with a top elevation of 62.5 feet and a weir elevation of 60.5 feet. The riser is a 7-foot by 7-foot concrete structure connected to a 48-inch concrete discharge pipe. The discharge from Cell D routes to a small stream south of AP-1.

(xi) Provisions for surveillance, maintenance and repair:

Inspections of dikes are critical components and are conducted on a regular basis—at least annually by professional dam safety engineers and at least weekly by trained plant personnel. In addition, inspections are performed after unusual events such as storms. The inspections provide assurance that structures are sound and that action is taken, as needed, based on the findings. Safety inspections include numerous checklist items. Specific items vary from site to site but may include observations of such things as pond levels, weather conditions, rainfall since the prior inspection, instrument readings, conditions of slopes and drains; erosion, animal damage, ant hills, alignment of retaining structures and more. Dam safety engineers assess instrument readings, inspect any maintenance or remediation performed since the previous inspection, check the status of work recommended at prior inspections, ensure that the posting of emergency notification information is current and evaluate any items noted during plant personnel inspections.



(xii) Known record of structural instability:

There is no known record of structural instability for AP-1. An area of minor seepage on the downstream slope of Cell C was addressed with the installation of slot drains. Subsequent analysis confirmed the dikes structural stability.

Appendix



Plant McIntosh Ash Pond

N   **Ash Pond Location**

USA Topo Maps

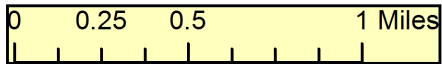

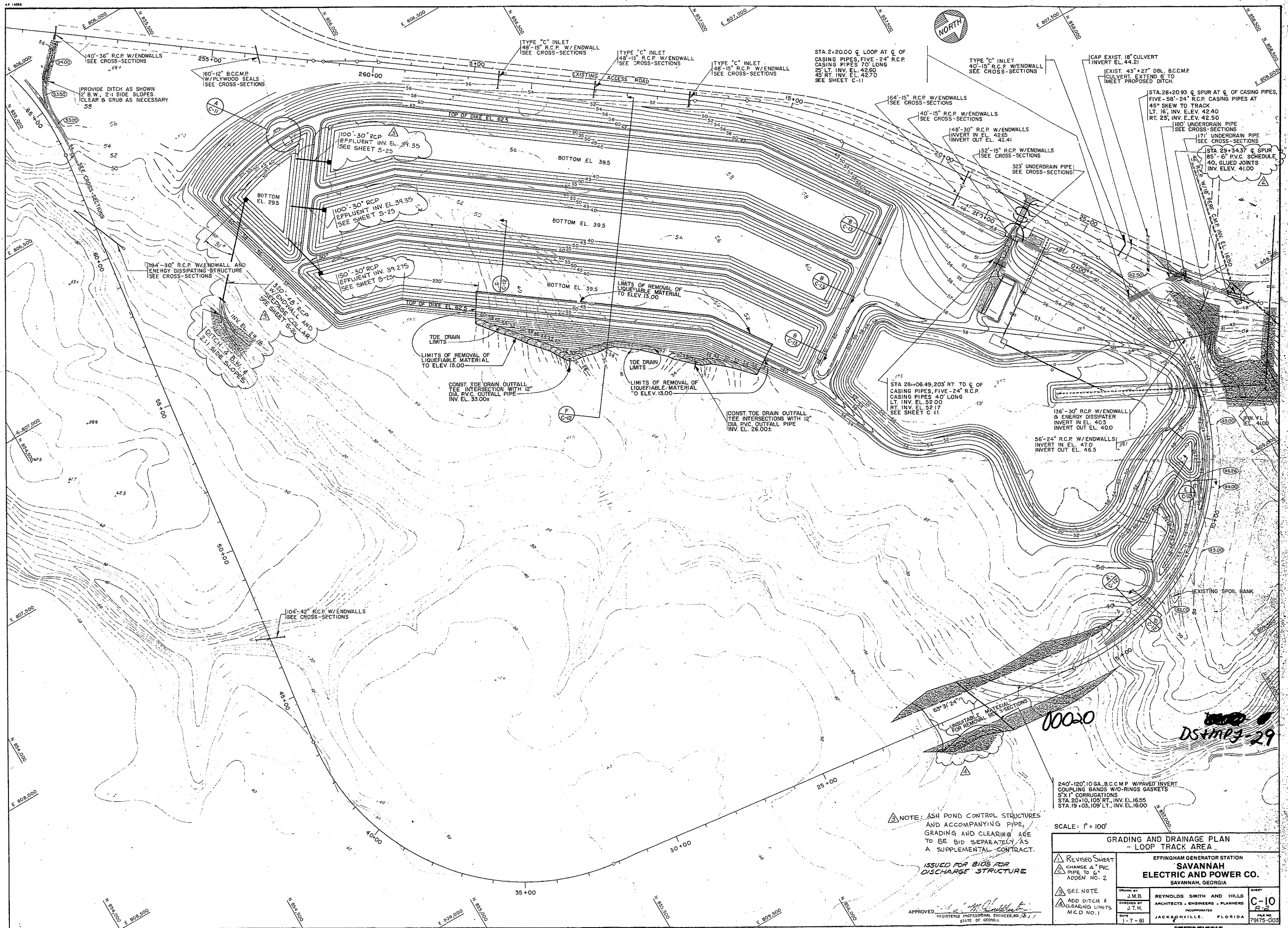

NOTE: ASH POND CONTROL STRUCTURES AND ACCOMPANYING PIPE, GRADING AND CLEARING ARE TO BE BID SEPARATELY AS A SUPPLEMENTAL CONTRACT.

ISSUED FOR BIDS FOR DISCHARGE STRUCTURE

240'-120' 10GA. B.C.C.M.P. W/PAVED INVERT COUPLING BANDS W/O-RINGS GASKETS SIX (6) CORRUPTIONS STA. 19+05.109' LT. INV. EL. 16.55 STA. 19+05.109' LT. INV. EL. 16.00

SCALE: 1" = 100'

REVISED SHEET CHANGE 4" PVC PIPE TO 6" ADDEN NO. 2		REYNOLDS SMITH AND HILLS ARCHITECTS - ENGINEERS - PLANNERS JACKSONVILLE, FLORIDA	SHEET C-10 FILE NO. 79175-003
SEE NOTE ADD DITCH & CLEARING LIMITS			
APPROVED: <i>[Signature]</i> REGISTERED PROFESSIONAL ENGINEER, NO. 2717 STATE OF GEORGIA		DATE: 1-7-01	

Raise Sheet

DSIMPJ-29

00020

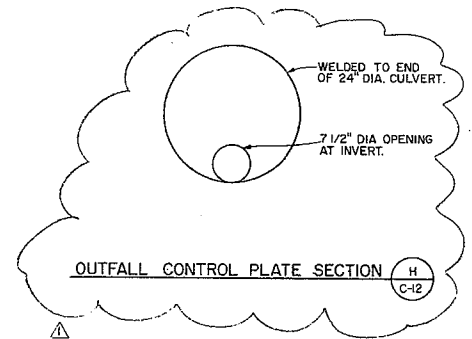
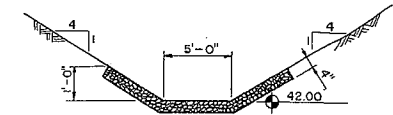
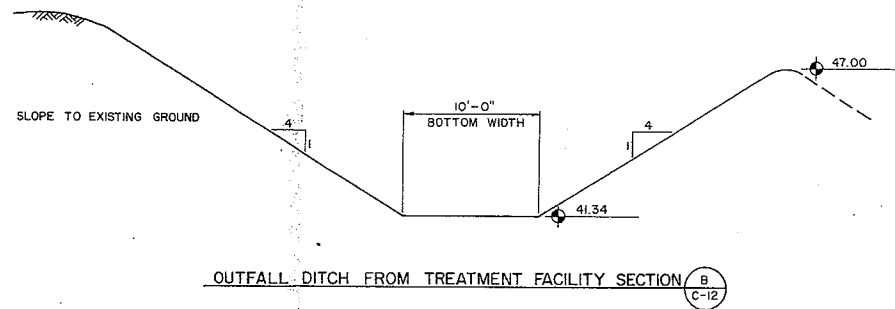
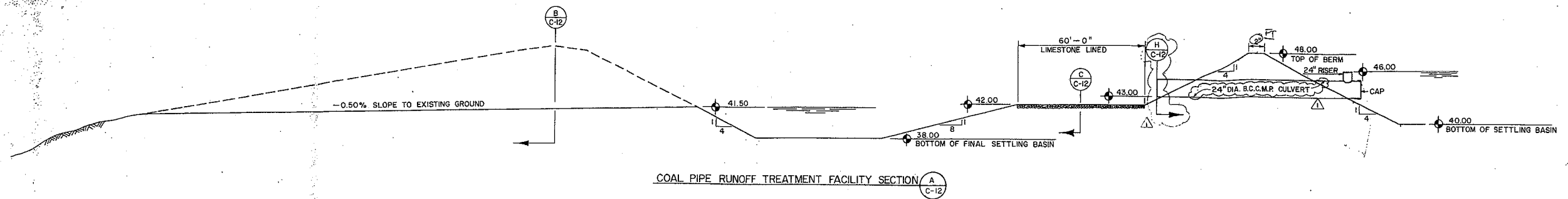

LIMESTONE LINED DITCH SECTION C
 NOTE: LIMESTONE IS TO BE NO. 3 STONE (AASHTO M-45), 1" TO 2 1/2" MIN. WITH 85% MIN. TOTAL CARBONATES

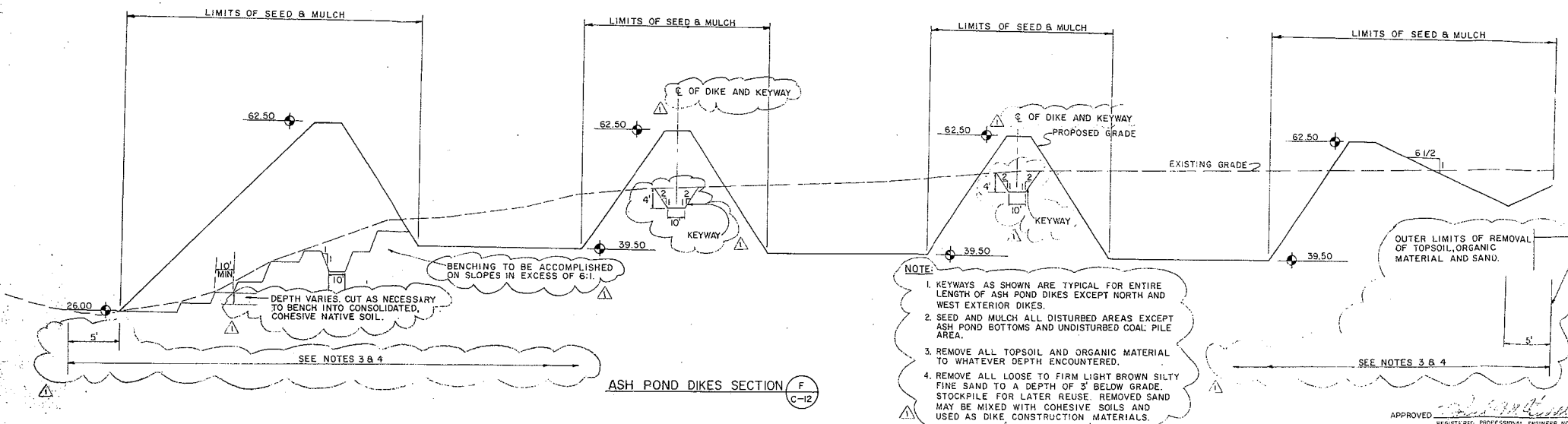
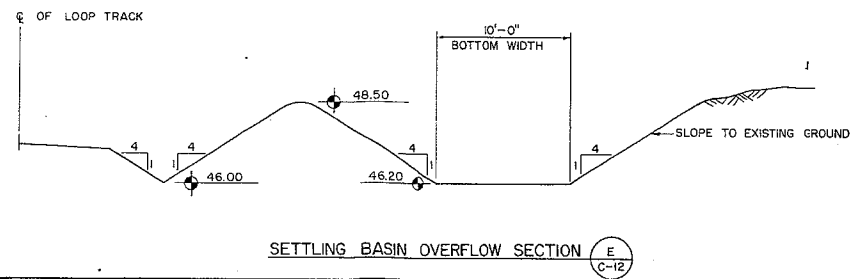
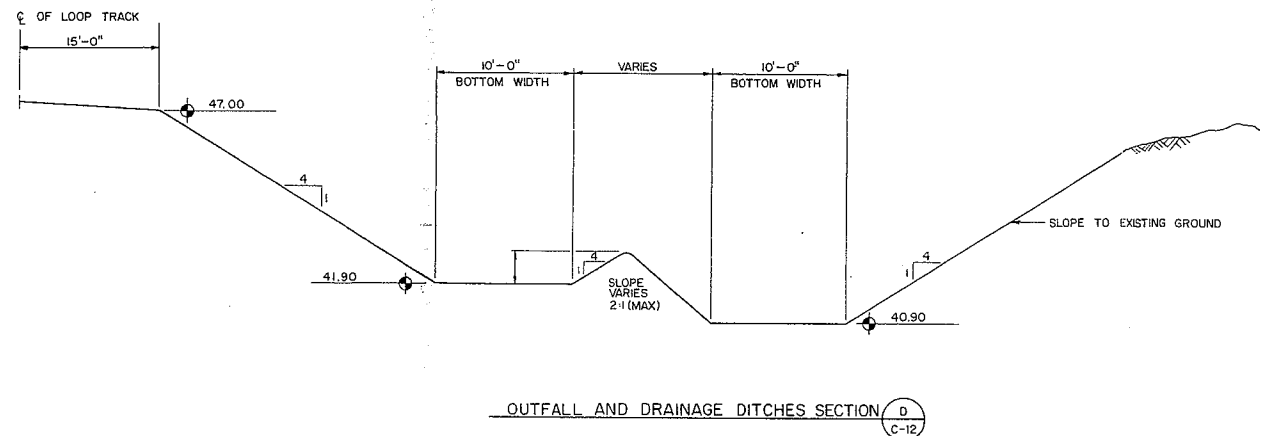

- NOTE:**
- KEYWAYS AS SHOWN ARE TYPICAL FOR ENTIRE LENGTH OF ASH POND DIKES EXCEPT NORTH AND WEST EXTERIOR DIKES.
 - SEED AND MULCH ALL DISTURBED AREAS EXCEPT ASH POND BOTTOMS AND UNDISTURBED COAL PILE AREA.
 - REMOVE ALL TOPSOIL AND ORGANIC MATERIAL TO WHATEVER DEPTH ENCOUNTERED.
 - REMOVE ALL LOOSE TO FIRM LIGHT BROWN SILTY FINE SAND TO A DEPTH OF 3' BELOW GRADE. STOCKPILE FOR LATER REUSE. REMOVED SAND MAY BE MIXED WITH COHESIVE SOILS AND USED AS DIKE CONSTRUCTION MATERIALS.

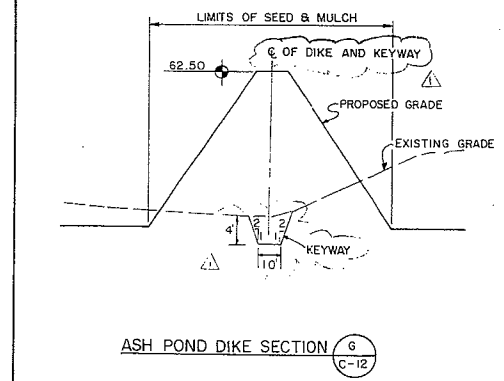

GENERAL NOTE:
 FOR GRADES ON DITCHES SEE GRADING AND DRAINAGE SHEET.
ADDENDUM NO. 1

GRADING AND DRAINAGE SECTIONS			
EFFINGHAM GENERATOR STATION SAVANNAH ELECTRIC AND POWER CO. SAVANNAH, GEORGIA			
DRAWN BY J.P.Z. CHECKED BY J.T.H. DATE 1-7-81	REYNOLDS, SMITH AND HILLS ARCHITECTS - ENGINEERS - PLANNERS JACKSONVILLE, FLORIDA	SHEET C-12 FILE NO. 79175-003	REVISED SHEET

APPROVED: [Signature]
 REGISTERED PROFESSIONAL ENGINEER, NO. 18,777
 STATE OF GEORGIA

1/4" NEOPRENE (7C DUND) CONT. UNDER RAIL (1" WIDE) FURNISHED AND INSTALLED BY CONTRACTOR.

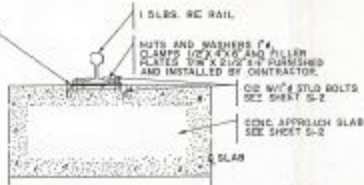

RAIL ON COAL UNLOADING HOPPER APPROACH SLAB

FILL WITH BITUMINOUS MATERIAL.

1/4" NEOPRENE (7C DUND) CONT. UNDER RAIL (1" WIDE) FURNISHED AND INSTALLED BY CONTRACTOR.

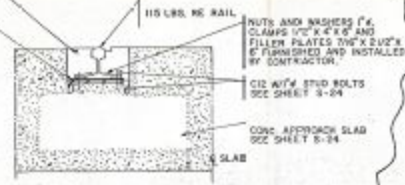

RAIL ON TRACK SCALE APPROACH SLAB

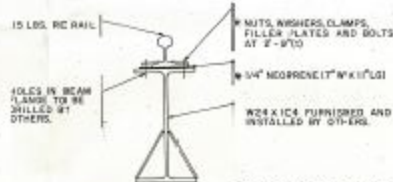

RAIL ON COAL UNLOADING HOPPER

* ITEMS MARKED THIS TO BE FURNISHED BY OTHERS AND TO BE INSTALLED BY CONTRACTOR.

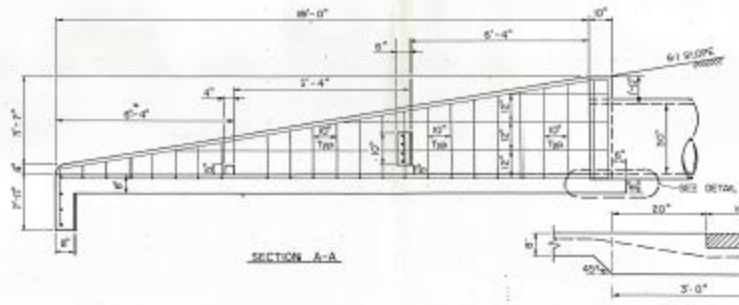

SECTION A-A

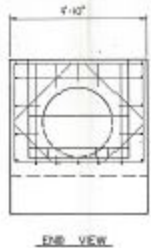

END VIEW

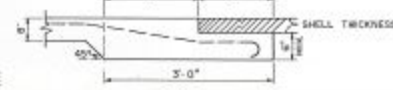

DETAIL A

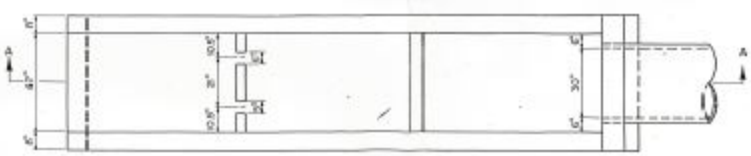

PLAN VIEW

ENERGY DISSIPATING ENDWALL DETAIL

- NOTE:
1. ALL REINFORCING STEEL IS 1/2" # BARS. ALL BAR DIMENSIONS ARE GIVEN OUT TO EXT. BAR CLEARANCE 2" EXCEPT AS NOTED.
 2. MATERIAL QUANTITIES:
CONCRETE: 4.88 CU. YD.
REINFORCING STEEL: 351 LBS.

APPROVED: PROJECT ENGINEER, CIVIL ENG. DIV. OF T&E

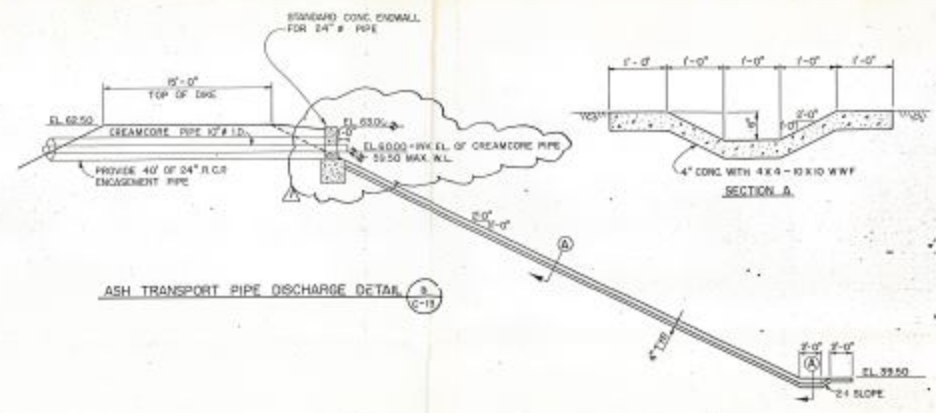

ASH TRANSPORT PIPE DISCHARGE DETAIL

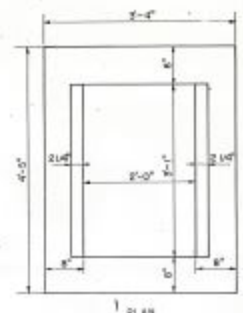

PLAN

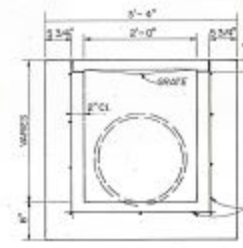

SECTION

RECOMMENDED MAXIMUM PIPE SIZE
6'-0" WALL - 18" PIPE
9'-1" WALL - 24" PIPE

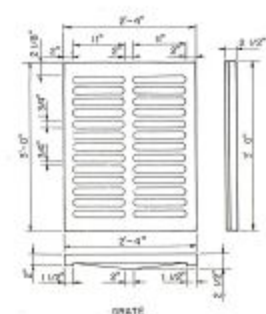

DITCH

DITCH BOTTOM INLET TYPE "C"

CONTRACTOR'S OPTION TO FURNISH SHOP DRAWINGS FOR BRICK, MASONRY OR PRECAST UNITS.

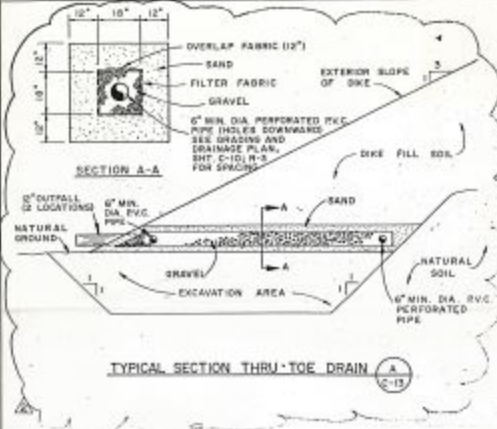

TYPICAL SECTION THRU TOE DRAIN

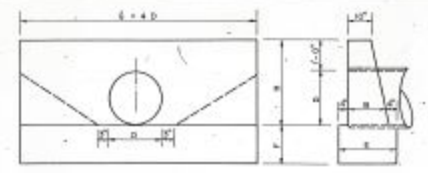

FRONT ELEVATION

SIDE ELEVATION

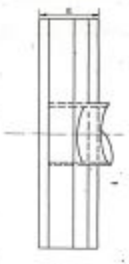

PLAN

DIMENSIONS

W	H	L	T	D	H
12"	12"	12"	12"	12"	12"
18"	18"	18"	18"	18"	18"
24"	24"	24"	24"	24"	24"
30"	30"	30"	30"	30"	30"
36"	36"	36"	36"	36"	36"
42"	42"	42"	42"	42"	42"
48"	48"	48"	48"	48"	48"

CONCRETE ENDWALL DETAIL MCB/S SHEET 368

DRAINAGE DETAILS

ASCD DETAIL

SAVANNAH ELECTRIC AND POWER CO. SAVANNAH, GEORGIA

REYNOLDS, SMITH AND HARRIS ARCHITECTS, ENGINEERS, PLANNERS SAVANNAH, GEORGIA

JACKSONVILLE, FLORIDA

500097 TYPICAL SHEET 010
NOV-20-04
ISSUED FOR BIDDING

C-13
73.75.000

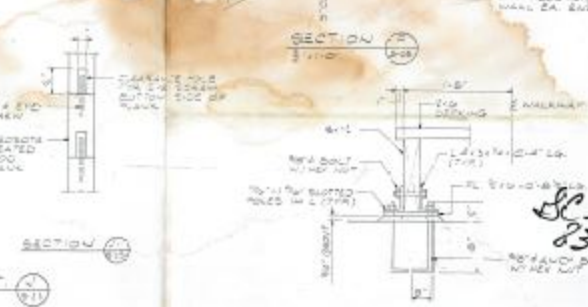
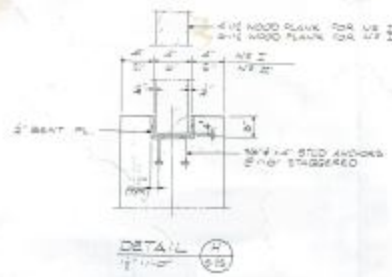
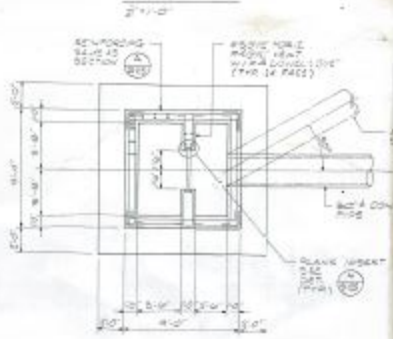
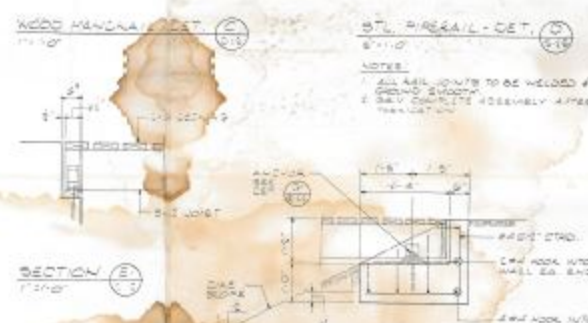
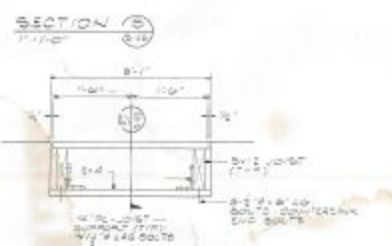
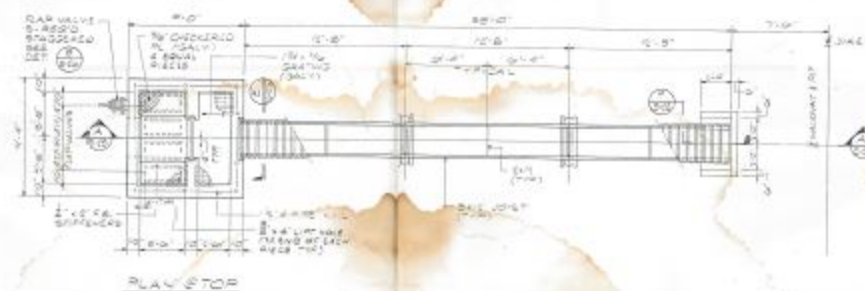
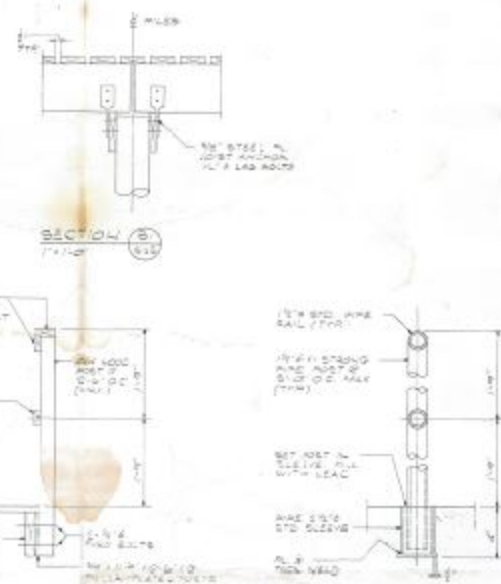
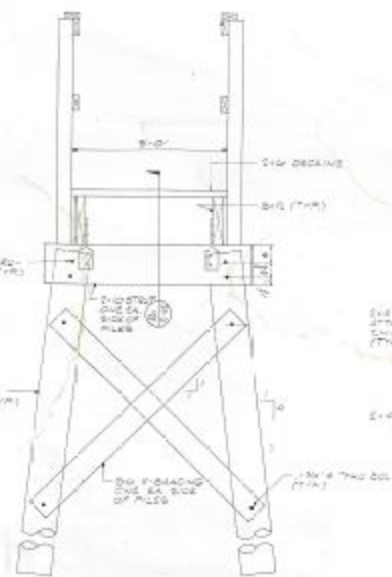
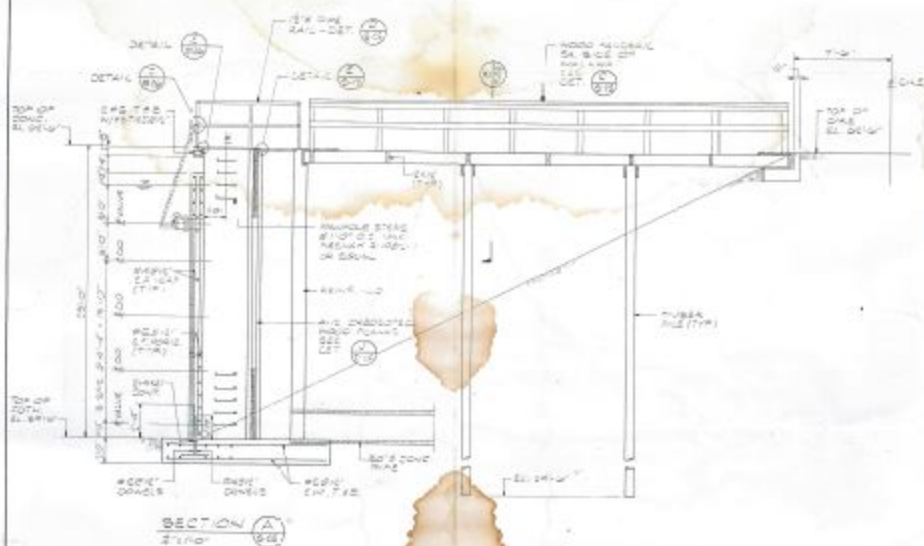

NOTE
FOR LOCATION OF DIMENSION STRUCTURE
SEE SHEETS C-4 & C-5

DISCHARGE STRUCTURE TYPE I
PLANS, SECTIONS AND DETAILS

SPRINGMAN GENERATOR STATION
SAVANNAH
ELECTRIC AND POWER CO.
SAVANNAH, GEORGIA

DATE	REVISED	BY	NO.
M. E. S.	REYNOLDS, SMITH AND HARRIS		
1937	SAVANNAH, GEORGIA		
1937	SAVANNAH, GEORGIA		
1937	SAVANNAH, GEORGIA		

S-25

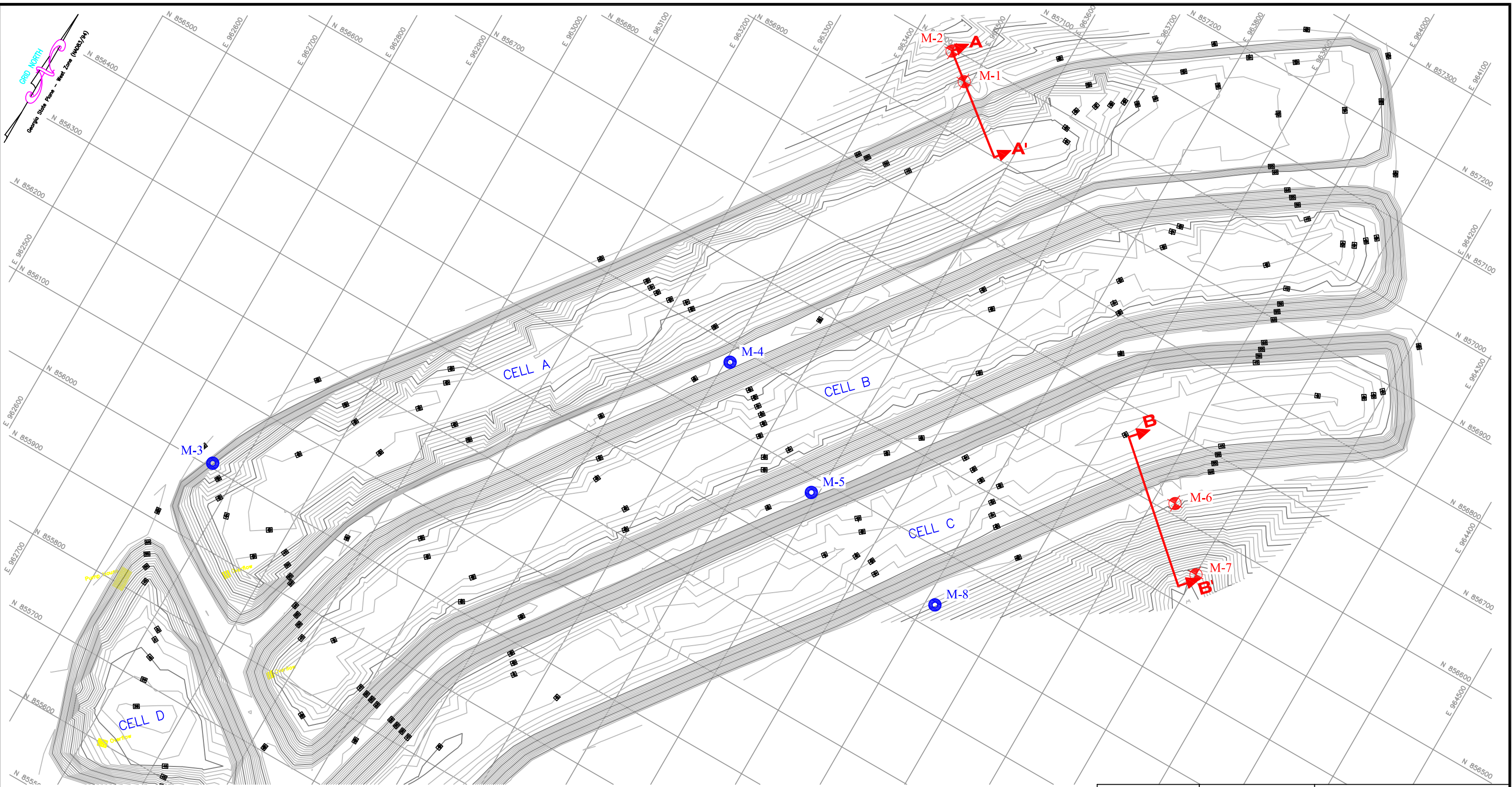

- Legend:**
- M-7 Well
 - M-3 Soil Boring

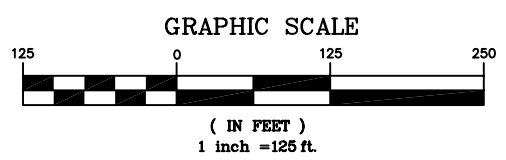

Southern Company Services, Inc.
 Copyright © Southern Company Services, Inc. All Rights Reserved
 This document contains proprietary, confidential, and/or trade secret information of the subsidiaries of The Southern Company or of third parties. It is intended for use only by employees of, or authorized contractors of, the subsidiaries of the Southern Company. Unauthorized possession, use, distribution, copying, dissemination, or disclosure of any portion hereof is prohibited.

ATTACHMENT A – FIGURE 1
 PLANT MCINTOSH CALC. # TV-MC-3160BW-001
 BORING & WELL LOCATIONS
 CROSS SECTIONS A-A' & B-B'

BY	CHK'D	DATE		
Southern Company Generation Engineering and Construction Services FOR				
Georgia Power Company				
SCALE	DRAWING NUMBER	SHEET	CONT'D	REV
AS SHOWN	ES1896S2	1	FINAL	0

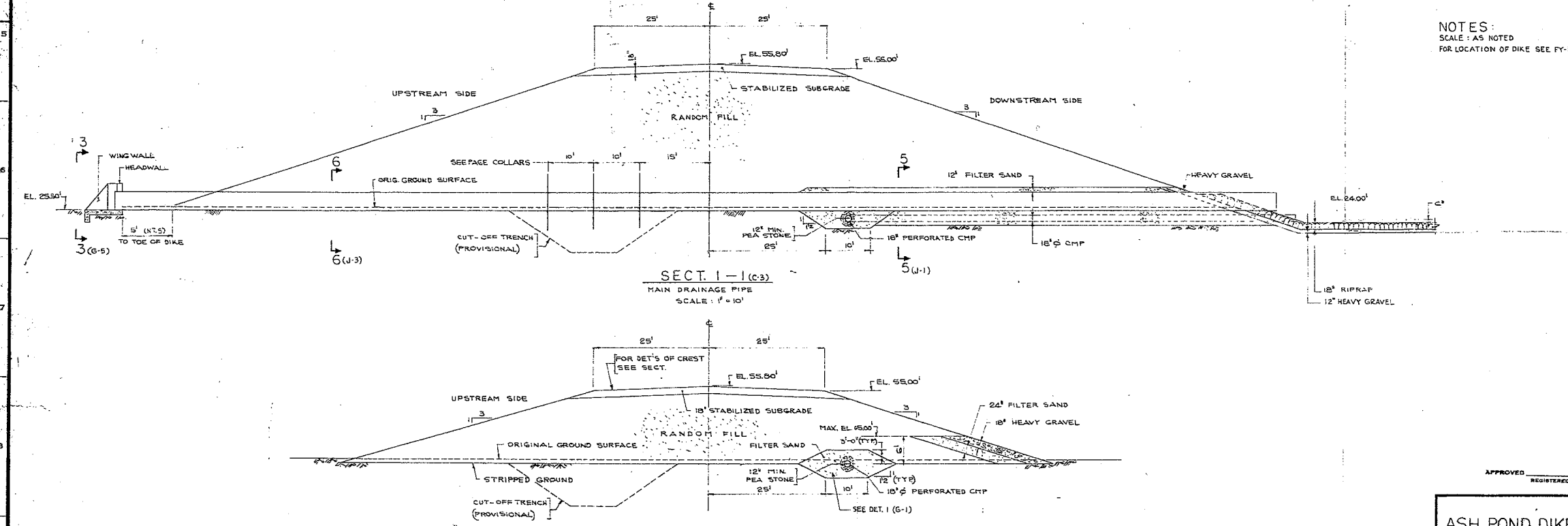
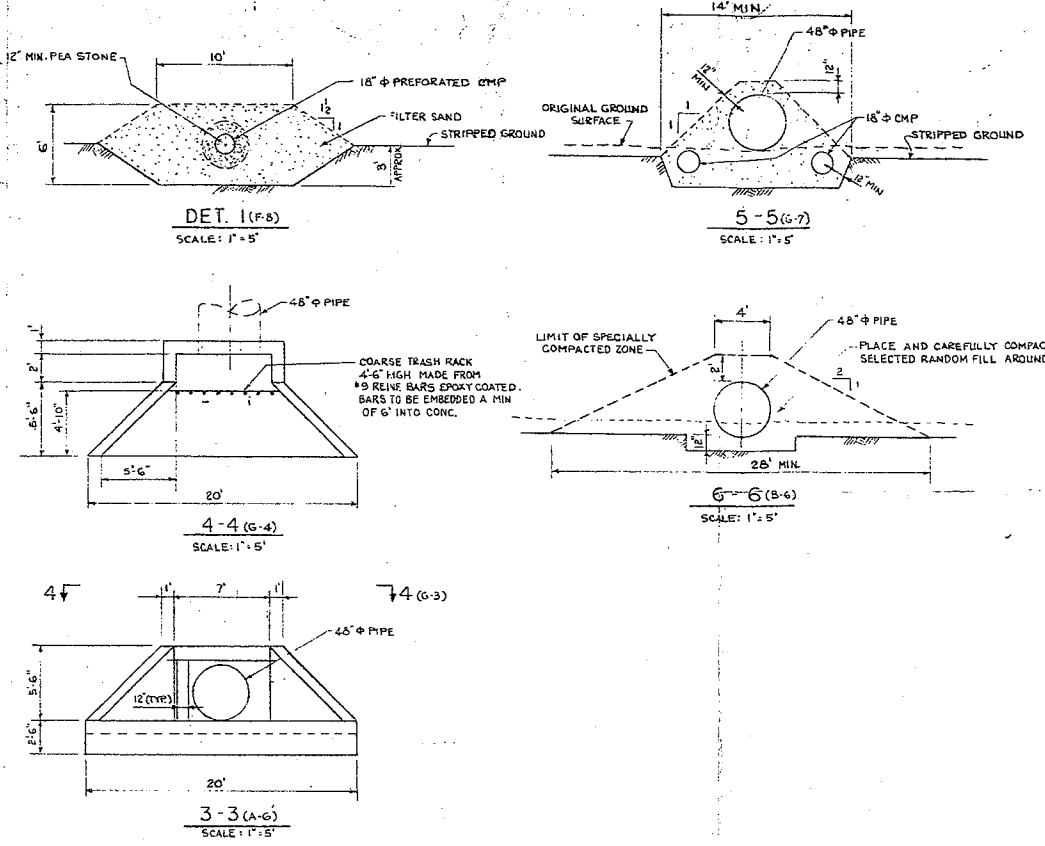
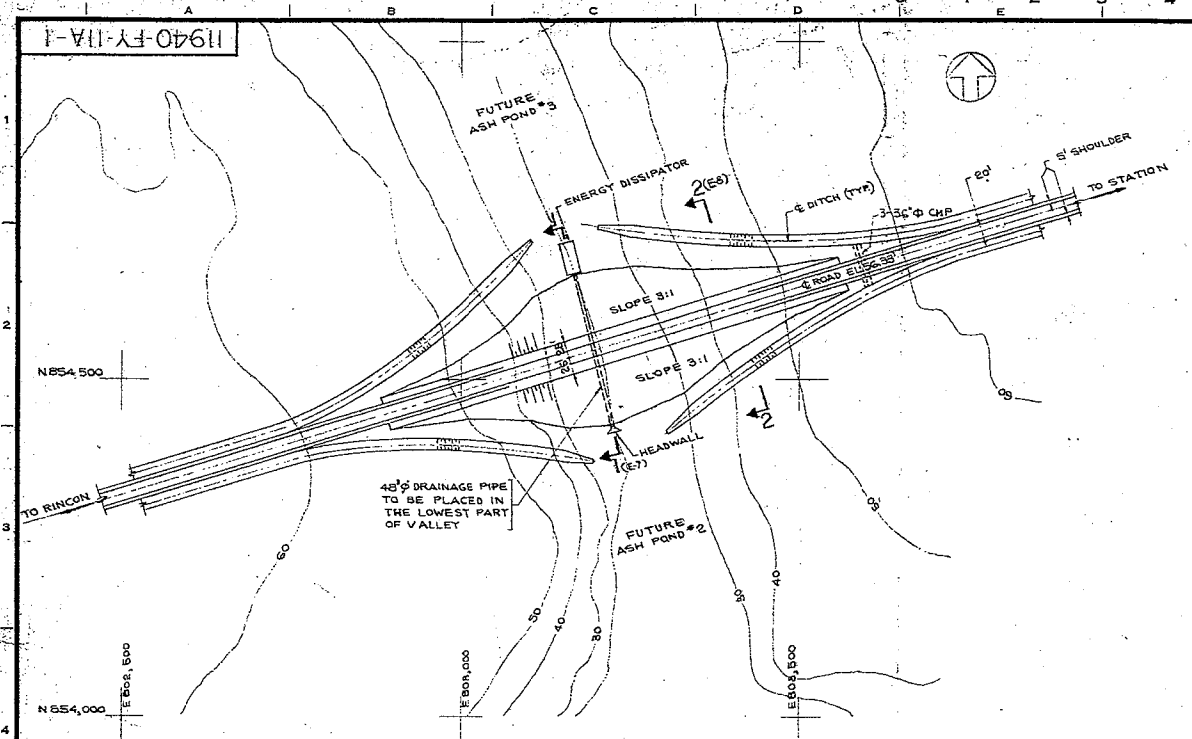

NOTES:
SCALE: AS NOTED
FOR LOCATION OF DIKE SEE FY-SG & FY-SJ.

APPROVED _____
REGISTERED PROFESSIONAL ENGINEER, NO. _____
STATE OF GEORGIA

ASH POND DIKES-PLAN & SECTIONS

UNIT 1 - EFFINGHAM STATION
SAVANNAH ELECTRIC AND POWER CO.
SAVANNAH, GEORGIA

STONE & WEBSTER ENGINEERING CORPORATION
BOSTON, MASS.

DRAWING NUMBER: 11940-FY-UA-1

ISSUE	DESCRIPTION	CHND	COOR	APPR	DATE	ISSUE	DESCRIPTION	CHND	COOR	APPR	DATE	ISSUE	DESCRIPTION	CHND	COOR	APPR	DATE	ISSUE	DESCRIPTION	CHND	COOR	APPR	DATE
1	ORIGINAL ISSUE FOR BIDS ONLY																						

ARCH	CONC	STEEL	MECH	INST	VESS	HDR	STRESS	B.S.	ELEC	LTC

Designed by: MARINER
Checked by: CHK'd by

01:01:37 PM 6/21/2004 JLGALT